

HOEFLON[®] S800 GLASS SUCTION LIFTER

S800 Specifications

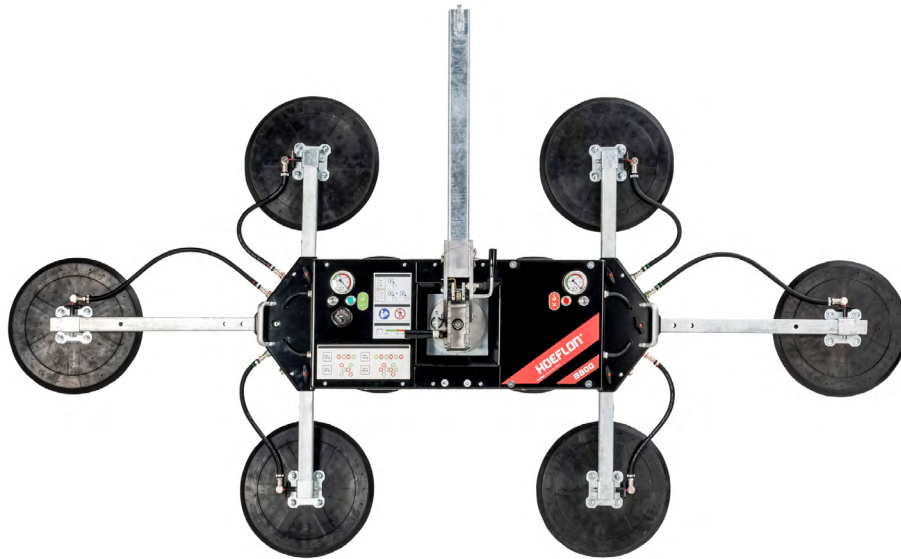

Lifting capacity Dual Circuit:	400 / 600 / 800 kg
Machine weight:	64 / 73 / 82 kg
Rotation range:	360° with four locking positions
Tilting range:	90° with six locking positions
Machine height:	190 mm
Battery:	12VDC, 10Ah

S800 Specifications

The Hoeflon S800 suction lifter is a premium quality multifunctional glass lifter, with exceptional fit and finish, at a very competitive price.

All our products are designed in-house in close cooperation with users from the field. This results in products that are a class apart when it comes to the details and provide the user with every convenience in daily use.

Unique features

- Can be used as both spider and inline suction lifter.
- At just 82 kg with a lifting capacity of 800 kg, it is the lightest suction lifter in its class.

Delivered standard with:

- Radio remote control
- Transport trolley
- Shortened lifting arm
- Legs
- Quick-change battery
- Protective covers for suction cups

Accessories



Battery

Battery charger

Remote control

Lifting arm

Specifications

- ▶ Extra-short lifting arm provides very compact dimensions for when glass installation space is limited.
- ▶ Angle adjustment on the Hoeflon lifting arm provides extra safety and convenience for indoor glazing installation because the angle can be fixed in different positions.
- ▶ Double vacuum circuit, meeting the requirements of the EN 13155 directive, ensures maximum safety and installation speed because external load fall arrester is no longer necessary.
- ▶ Radio remote control provides extra installation speed and convenience.
- ▶ The overall width of the machine is very low, which means that work can also be carried out between the façade and scaffolding.

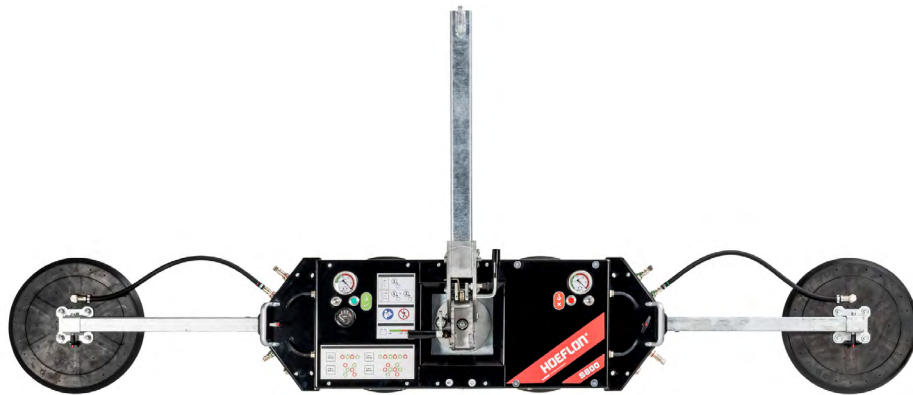

S800 Specifications

SWL 800 kg - Spider suction lifter (82 kg)

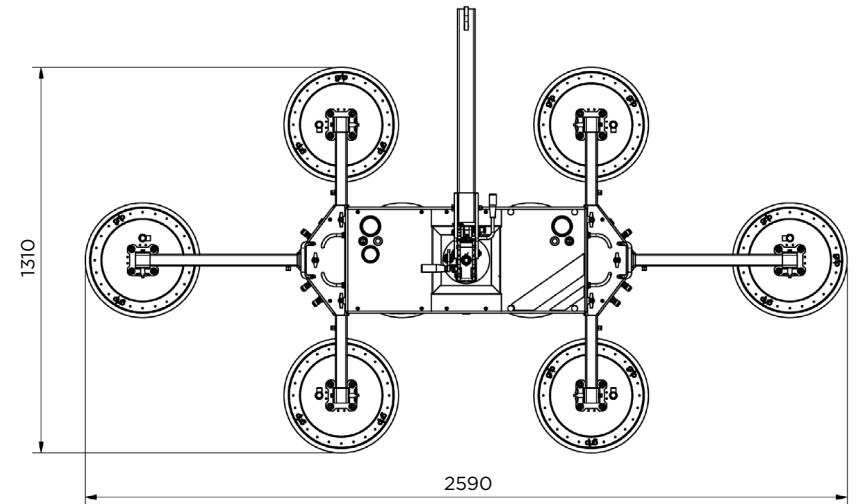

SWL 600 kg - Inline suction lifter (73 kg)

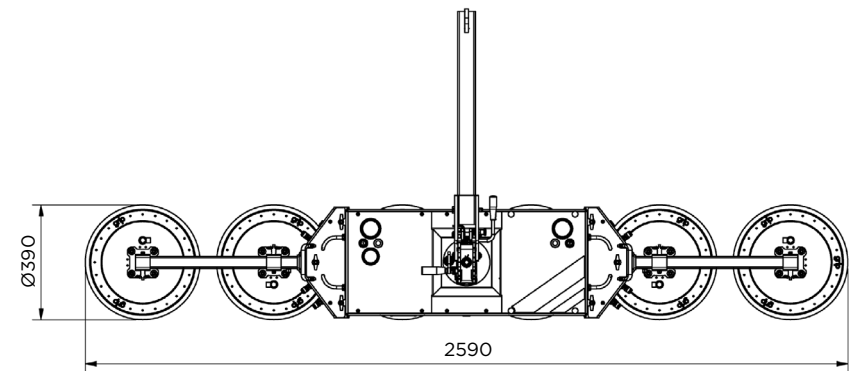

SWL 400 kg - Inline suction lifter (64 kg)

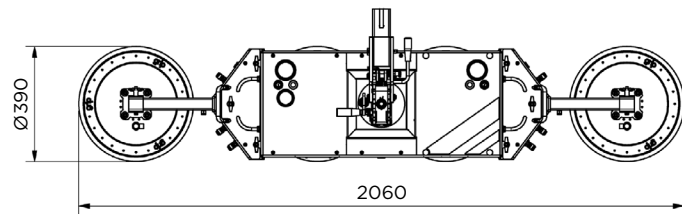

Hoeflon machines are functional and offer optimal power and reliability. We offer many possibilities and help you come up with solutions.

SWL 200 kg - Base unit (51 kg)

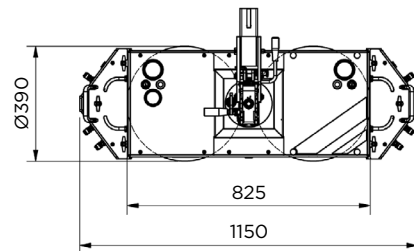

Monitor Lifts Training & Support



Operator Training



Service Training



24/7 Support



Service Trailer



UTE/Trucks



Service Training

Get In Touch

- monitor.net.au
- sales@monitor.net.au
- 1800 025 024 (free call)

Our Locations

- TAMWORTH**
143 Gunnedah Road, Tamworth NSW 2340
- SYDNEY**
9 Brumby Street, Seven Hills NSW 2147
- MELBOURNE**
75 Willandra Drive, Epping VIC 3076
- BRISBANE**
- CABOOLTURE**
2/2 Alta Drive, Caboolture QLD 4510
- PERTH**
- NEW ZEALAND**
Youngman Richardson & Co. Ltd.
Branches: Auckland, Wellington, Christchurch