

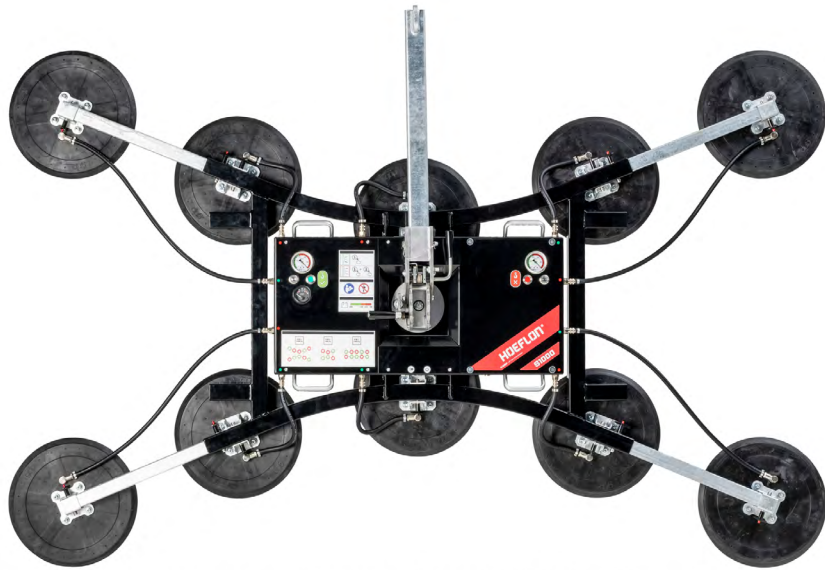

HOEFLON[®] S1000 GLASS SUCTION LIFTER

S1000 Specifications



Lifting capacity Dual Circuit:	600 / 1000 kg
Machine weight:	85 / 110 kg
Rotation range:	360° with four locking positions
Tilting range:	90° with six locking positions
Machine height:	190 mm
Battery:	12VDC, 10Ah

S1000 Specifications

The Hoeflon S1000 suction lifter is a premium quality multifunctional glass lifter, with exceptional fit and finish, at a very competitive price.

All our products are designed in close cooperation with users from the field. This results in products that are a class apart when it comes to the details and provide the user with every convenience in daily use.

Unique features

- Compact basic unit for glass with small dimensions
- Spider shape with large spread provides greater ease of installation, speed and safety with large-sized glass
- Lightweight design

Delivered standard with:

- Remote control
- Transport trolley
- Long lifting arm
- Short lifting arm
- Swappable battery system incl. spare battery
- Protective covers for suction cups

Accessories



Battery

Battery charger

Remote control

Lifting arm

Specifications

- ▶ Short lifting arm provides very compact dimensions for when glass installation space is limited
- ▶ Long lifting arm allows almost vertical hanging of large-sized glass
- ▶ Angle adjustment on the Hoeflon lifting arm provides extra safety and convenience for indoor glazing installation because the angle can be fixed in different positions
- ▶ Double vacuum circuit, meeting the requirements of the EN 13155 directive, ensures maximum safety and installation speed because external fall protection is no longer necessary
- ▶ Radio remote control provides extra installation speed and convenience
- ▶ The overall width of the machine is very low, which means that work can also be carried out between the façade and scaffolding



S1000 Specifications

SWL 600 kg - Spider suction lifter (85 kg)

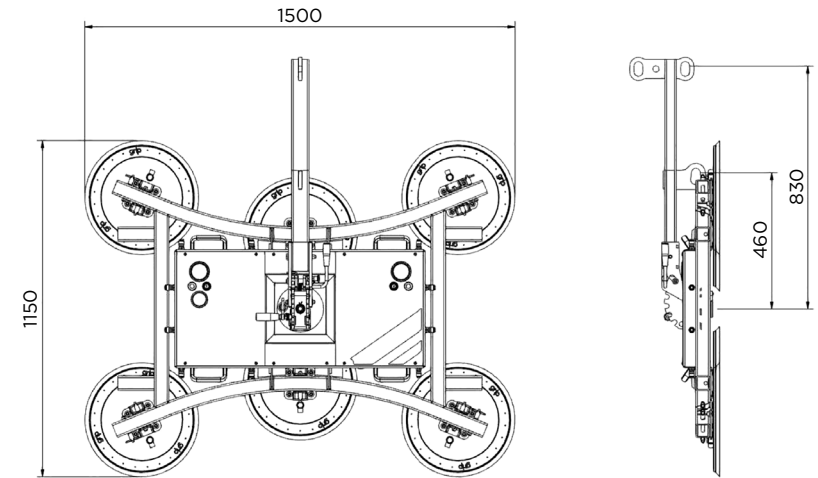

SWL 1000 kg - Inline suction lifter (110 kg)

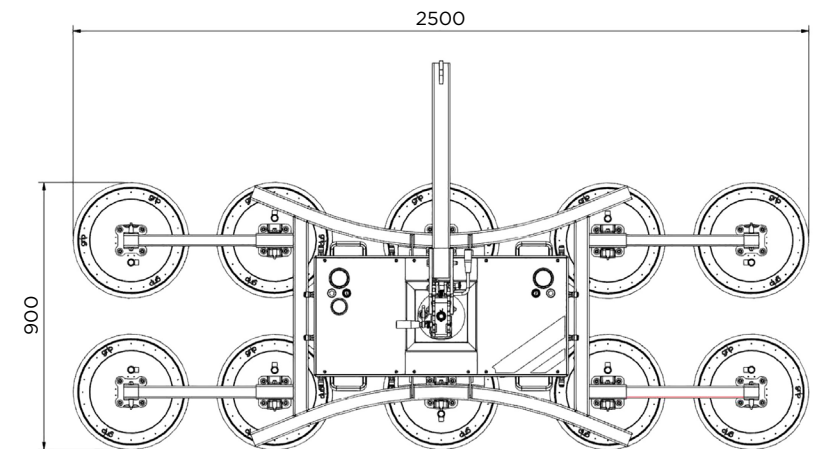

SWL 1000 kg - Spider suction lifter (110 kg)

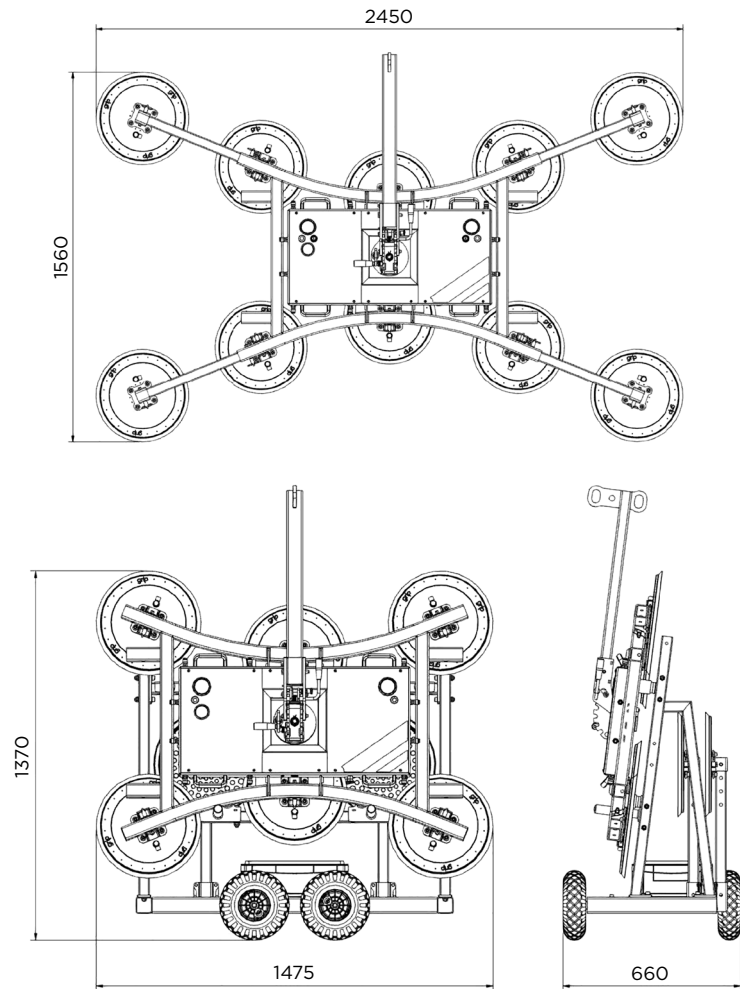

Hoefflon machines are functional and offer optimal power and reliability. We offer many possibilities and help you come up with solutions.



Monitor Lifts Training & Support



Operator Training



Service Training



24/7 Support



Service Trailer



UTE/Trucks









Service Training

Get In Touch

-  monitor.net.au
-  sales@monitor.net.au
-  1800 025 024 (free call)

Our Locations

-  **TAMWORTH**
143 Gunnedah Road, Tamworth NSW 2340
-  **SYDNEY**
9 Brumby Street, Seven Hills NSW 2147
-  **MELBOURNE**
75 Willandra Drive, Epping VIC 3076
-  **BRISBANE**
-  **CABOOLTURE**
2/2 Alta Drive, Caboolture QLD 4510
-  **PERTH**
-  **NEW ZEALAND**
Youngman Richardson & Co. Ltd.
Branches: Auckland, Wellington, Christchurch